

Understanding Happiness: A Study on the Influence of Emotional Intelligence and Life Satisfaction in Adults

Entendiendo la Felicidad: Un estudio sobre la influencia de la Inteligencia Emocional y la Satisfacción con la Vida en adultos

-  Elizabeth Gloria Tapia Salas | Universidad Privada de Tacna, Perú
-  Lourdes Melina Suarez Guevara | Universidad Privada de Tacna, Perú
-  Belinda Yauri Illapuma | Universidad Privada de Tacna, Perú
-  Sugey Milagros Calderón Carazas | Universidad Privada de Tacna, Perú
-  Miguel Angel Fernandez Esteba | Universidad Privada de Tacna, Perú

Fecha de recepción: 12.08.2023

Fecha de aprobación: 14.01.2024

Fecha de publicación: 15.02.2024

Cómo citar: Tapia, E., Suarez, L., Yauri, B., Calderón, S. & Fernandez, M. (2024). Understanding Happiness: A Study on the Influence of Emotional Intelligence and Life Satisfaction in Adults. *Psiquemag* 13 (1), e130106.

<https://doi.org/10.18050/psiquemag.v13i1.2790>

Abstract

The main purpose of this study focuses on developing an explanatory model of subjective happiness in adults in Tacna, integrating emotional intelligence and life satisfaction as central variables. The sample included 191 adults from Tacna, with a gender distribution comprising 54% women and 46% men. Three structural equation models were applied to examine subjective happiness in this population. In Model 1, a Chi-square ratio over degrees of freedom (X^2/GL) of 1.644 was recorded, with a Comparative Fit Index (CFI) of 0.933, a Tucker-Lewis Index (TLI) of 0.919 and a Parsimony-Normed Fit Index (PNFI) of 0.702. In Model 2, after the elimination of one predictor, an X^2/GL of 1.527, CFI of 0.951, TLI of 0.939 and PNFI of 0.709 were observed. By incorporating a covariance in Model 3, improvements were evident, with an X^2/GL of 1.438, CFI of 0.959, TLI of 0.949 and PNFI of 0.706. The most significant correlation was observed between subjective happiness and emotional intelligence, with a p-value of 0.004. No significant differences in happiness, intelligence and satisfaction were found between women and men when comparing by gender. These results indicate that Model 3 presents the strongest fit and a significant correlation between happiness and emotional intelligence.

Keywords: Subjective happiness, Emotional intelligence, Life satisfaction, Adults.

Resumen

El propósito central de este estudio se enfoca en desarrollar un modelo explicativo de la felicidad subjetiva en adultos de Tacna, integrando la inteligencia emocional y la satisfacción con la vida como variables centrales. La muestra abarcó a 191 adultos de Tacna, con una distribución de género que comprendió el 54% de mujeres y el 46% de hombres. Se aplicaron tres modelos de ecuaciones estructurales para examinar la felicidad subjetiva en esta población. En el Modelo 1, se registró un cociente Chi-cuadrado sobre grados de libertad (X^2/GL) de 1.644, con un Índice de Ajuste Comparativo (CFI) de 0.933, un Índice de Tucker-Lewis (TLI) de 0.919 y un Índice de Ajuste Normado por Parsimonia (PNFI) de 0.702. En el Modelo 2, luego de la eliminación de un predictor, se observó un X^2/GL de 1.527, CFI de 0.951, TLI de 0.939 y PNFI de 0.709. Al incorporar una covarianza en el Modelo 3, se evidenciaron mejoras, con un X^2/GL de 1.438, CFI de 0.959, TLI de 0.949 y PNFI de 0.706. La correlación más significativa se observó entre la felicidad subjetiva y la inteligencia emocional, con un valor p de 0.004. No se encontraron diferencias significativas en la felicidad, inteligencia y satisfacción entre mujeres y hombres al realizar comparaciones por género. Estos resultados señalan que el Modelo 3 presenta el ajuste más sólido y una correlación significativa entre la felicidad y la inteligencia emocional.

Palabras clave: Felicidad subjetiva, Inteligencia emocional, Satisfacción con la vida, Adultos.

INTRODUCCIÓN

The crisis triggered by the COVID-19 pandemic has emerged as one of the most shocking events in the world population in recent years, as corroborated by reports from the Neuropsychology Service of the National Institute of Neurological Sciences. This situation has revealed remarkable psychological distress in the population, characterized by emotional and social imbalances (Rodríguez et al., 2021). In this context, the understanding of subjective happiness is of particular relevance to scientific research. With the purpose of addressing the essential elements that contribute to subjective happiness among adults residing in the city of Tacna, this study focuses on the integration of emotional intelligence and life satisfaction as crucial variables. Based on the theoretical contributions of prominent authors and the use of their respective measurement instruments, our objective is to construct an explanatory model that sheds light on the complexity of the experience of happiness in this specific context. According to the definition of Daniel Goleman, one of the pioneers in the study of emotional intelligence, this is defined as “the ability to recognize, understand and manage our own emotions, as well as those of others” (Goleman, 1995). This highlights the close relationship between emotional intelligence, emotional regulation, and adaptation to different situations, suggesting its possible influence on subjective well-being.

On the other hand, life satisfaction has been conceptualized as a global cognitive evaluation that individuals make of their existence, considering aspects such as the achievement of goals, satisfactory interpersonal relationships, and a sense of purpose (Diener, 1984). This dimension of subjective well-being has been the subject of numerous investigations that have explored its determinants and consequences in various populations. Brackett and Salovey’s (2006) assertion emphasizes that “as people develop their emotional intelligence, they are better able to handle stressful situations and find greater well-being in their lives.” This observation evidences the possible relationship between emotional intelligence and happiness in adults, highlighting the importance of emotional skills in the pursuit of well-being. In a similar vein, Lyubomirsky et al. (2005) note that “life

satisfaction is closely related to the perception of control over one’s life and the ability to achieve meaningful goals.” This link between life satisfaction and aspects such as control and self-fulfillment suggests its relevance to the overall experience of happiness. However, as Ciarrochi et al. (2007) cautioned, “the relationship between emotional intelligence and life satisfaction is not yet fully understood, and more research is needed to explore its underlying mechanisms.” This call for research highlights the need for studies that delve deeper into the relationship between these variables and their influence on subjective well-being. Subjective happiness, understood as an emotional and subjective state that encompasses well-being, satisfaction, and joy in life, constitutes the epicenter of this study. The Subjective Happiness Scale by Sonja Lyubomirsky and Heidi S. Lepper (1999), adapted by Extremera Pacheco and Fernandez Berrocal (2019), an instrument that, through its subjective approach, enables a comprehensive assessment of the individual perception of happiness, was used. This scale, which consists of four items, has proven to be psychometrically sound, supported by research conducted in the United States and Russia. Its internal consistency, as well as its convergent and discriminant validity, make it a reliable tool for measuring subjective happiness.

Consequently, this research aims to understand the complex interrelationships between emotional intelligence, life satisfaction, and subjective happiness in adults living in Tacna during the year 2023. Based on the hypothesis that subjective happiness is determined by emotional intelligence and life satisfaction, our general objective is to evaluate the adjustment of subjective happiness based on these variables in the population above. Specific objectives include assessing the influence of emotional intelligence and life satisfaction on subjective happiness, as well as exploring the relationships between these variables and subjective happiness.

METHOD

Research Design

The methodological framework adopted in this study is non-experimental, based on a cross-sectional and correlational design. This selection

is justified by the main objective of investigating the interactions between the variables of emotional intelligence, life satisfaction, and subjective happiness in adults residing in Tacna. This design facilitates the description of the relationship between the three study variables at a specific time (Hernández Sampieri et al., 2014).

In addition, a quantitative approach was applied for data analysis, given that quantitative statistical techniques such as correlations, regressions, and analysis of variance were used. These techniques

allowed for examining the relationships between emotional intelligence, life satisfaction, and happiness (Hernández et al., 2018).

Sample

The sample analyzed consisted of 191 adults living in Tacna, all over 18 years of age, which ensured a diverse representation of the local population. Specifically, it was found that 54% of the participants were women, with a total of 104 individuals, while the remaining 46% were men, reaching a total of 87 participants.

Table 1

Frequency by sex

Sex	Frequencies	% del Total	% Accumulated
Female	104	54.5 %	54.5 %
Male	87	45.5 %	100.0 %

Instruments

The Subjective Happiness Scale (Lyubomirsky & Lepper, 1999).

It is an adaptation of Sonja Lyubomirsky and Heidi S. Lepper's Subjective Happiness Scale, the original version of which was developed as part of a study that culminated in the article "A Measure of Subjective Happiness: Preliminary Reliability and Construct Validation," accepted in November 1997. This tool was designed to measure subjective happiness, which is defined as an emotional and subjective state that encompasses well-being, satisfaction, and joy in life. Lyubomirsky and Lepper proposed the development of a reliable and valid instrument to assess individual perception of happiness. The version used in this study is an adaptation made by Extremera Pacheco et al. in 2019, which includes additional adjustments and validations to adapt the scale to different contexts and populations. The Subjective Happiness Scale consists of four items and employs a Likert-type scale in which participants evaluate their level of happiness in relation to various statements. The validity and reliability of this scale have been confirmed by studies carried out in the United States and Russia, consolidating it as a reliable psychometric tool for measuring subjective happiness in research related to positive psychology. The reliability analysis of the instrument was based

on Cronbach's Alpha coefficient, with results indicating reliability values of 0.73 for adults, 0.76 for university students, and 0.87 for adolescents. The correlations between the items and the total score ranged between 0.33 and 0.67 for adults, between 0.51 and 0.66 for university students, and between 0.64 and 0.80 for adolescents. To assess construct validity, a factor analysis was performed, revealing acceptable correlation matrix adequacy indices in the three samples, with KMO values between 0.70 and 0.79. In addition, in Bartlett's test of sphericity, all cases were significant ($p < 0.01$).

Trait Emotional Intelligence Questionnaire (TEIQue-SF) (Short Version) (Neri-Uribe & Juárez-García, 2016).

The TEIQue instrument, which originated from Petrides' doctoral thesis in 2001, was designed with the purpose of assessing emotional intelligence as a personality trait, positioning it at lower levels of the personality hierarchy. Initially, the original version consisted of 153 items and has been translated into more than 15 languages, consolidating itself as a tool widely used in research and studies related to emotional intelligence. Through his research, Petrides has made significant contributions to the understanding and assessment of emotional intelligence as an intrinsic component of personality. Over time, more concise versions of

the TEIQue have been developed, such as the Trait Emotional Intelligence Questionnaire Short Version (TEIQue-SF), which consists of 30 items and has been used in studies with university students in Mexico. In an attempt to analyze the psychometric characteristics of this instrument, a study carried out by Neri-Uribe J and Juárez-García revealed reduced reliability levels for the factors of the original scale (Cronbach's alpha between 0.32 and 0.82; omega coefficient between 0.16 and 0.83) and failed to confirm the original structure in the confirmatory factor analysis ($\chi^2=768.47$, $gl=390$ and $p=0.0000$, $CFI=0.65$, $RMSEA=0.008$, $90\% CI=0.071-0.087$).

The Satisfaction with Life Scale (SWLS) (Atienza et al., 2000)

This adaptation of the Satisfaction with Life Scale is based on the original work of psychologists Ed Diener, Robert A. Emmons, Randy J. Larsen, and Sharon Griffin, who developed it as a measure of the cognitive component of well-being in 1985. The Spanish version of the scale, developed by Atienza, Pons, Balaguer, and García-Merita in 2000, includes adjustments and validations aimed at adapting it to the specific Spanish-speaking cultural and linguistic context. It is composed of five statements that participants evaluate using a seven-point Likert scale, ranging from "strongly disagree" to "strongly agree," focusing on the general perception of life satisfaction among adolescents. Internal consistency analysis through Cronbach's Alpha coefficient yielded a value of $\alpha = 0.84$. In addition, an exploratory factor analysis using the principal axis method identified a unidimensional structure. This single factor explained 53.7% of the total variance, and the factor values of the five items ranged from 0.63 (item 4) to 0.83 (item 3). Bartlett's test of sphericity indicated that the items were not independent ($p<0.001$), while the Kaiser-Meyer-Olkin coefficient suggested an adequate explanation of the correlations ($K-M-O = 0.86$). The single-factor structure explained 53.7% of the variance, with factor values between 0.63 and 0.83. Confirmatory factor analysis showed a good fit to the five-response-choice model. Positive associations were found between happiness and school satisfaction, as well as a negative correlation with loneliness, in terms of construct validity ($r = 0.046$; $p<0.001$ for happiness, $r = 0.32$; $p<0.001$ for school satisfaction, $r = -0.31$; $p<0.001$ for loneliness). These associations were especially notable among college students,

where the correlations and Variances-Covariance matrix were significant ($p<0.01$). Analysis of covariance showed adequate fit, supported by NFI, NNFI, CFI, and IFI indices $> .95$, a non-significant $SB\chi^2$ test ($p>.5$), and an $SB\chi^2/gl$ ratio < 2 . The proportion of variance explained was $> .43$, indicating an adequate adaptation of the SWLS scale to Spanish.

Study variables

Endogenous variable: Subjective Happiness (SF).

Subjective happiness is defined as the personal evaluation of one's happiness, which is unidimensional. It is measured through four items: F1, F2, F3, and F4, with seven possible responses to each statement, ranging from:

"A not very happy person" (1) to "A very happy person" (7).

F1: In general, I consider myself.

F2: Compared to most of the people around me, I consider myself.
F3: Some people tend to be very happy. They enjoy life regardless of what happens and cope with most things. To what extent do you consider yourself such a person?

F4: Some people tend to be very unhappy. Although they are not depressed, they do not seem as happy as they would like to be. To what extent do you consider yourself such a person?

Table 2

Measures of adjustment of the Subjective Happiness scale

KMO	Bartlett
.70 Y .79	$p<.01$

Exogenous variables:

Emotional Intelligence (EI).

Emotional intelligence is composed of six dimensions: BI, ATC, EMO, SB, ATM and AD.

BI: Well-being (trait happiness, trait optimism, self-esteem).

ATC: Self-control (Stress management, low impulsivity, emotion regulation)

EMO: Emotionality (Trait empathy, emotion perception, emotion expression, relationships)

ATM: Self-motivation (Independent facet contributing to global trait intelligence).

SB: Sociability (Emotion management, assertiveness, social awareness)

AD: Adaptability (Independent facet contributing to global trait intelligence).

Table 3

Measures of adjustment of the Emotional Intelligence questionnaire.

X ²	X ² /gl	CFI	RMSEA	p-valor	IC	C. Omega
768.47	390	65	0.008	0.000	.071-.087	.16 a .83

Life Satisfaction (LCS)

Satisfaction with life, unidimensional. It is assessed by five variables:

S1, S2, S3, S4 and S5.

S1: The kind of life I lead resembles the kind of life I always dreamed of leading.

S2: The conditions of my life are excellent.

S3: I am satisfied with my life.

S4: So far I have obtained the important things I want in life.

S5: If I could live again, I would like everything to be the same again.

Table 4

Measures of adjustment of the Satisfaction with Life scale.

CFI	KMO	Bartlett
0.95	0.86	p<0.001

Procedure

In the framework of the study on the Explanatory Model of Happiness in Adults in Tacna, a survey dissemination strategy was implemented through social networks and the researchers' profiles. The purpose was to reach a wider and more diverse audience, thus facilitating the participation of a greater number of people and covering different segments of the local population.

The survey was conducted using three questionnaires adapted to the local context. First, the Subjective Happiness Scale, adapted by Extremera Pacheco and Fernandez Berrocal in 2019, was used. It consisted of four questions with answers on a 7-point scale. Then, the Trait Emotional Intelligence Questionnaire (TEIQue-SF) developed by Neri-Urbe and Juárez-García in 2016 was applied, consisting of six dimensions and 30 items, asking participants to respond sincerely on a 7-point scale. Finally, the Satisfaction with Life Scale adapted to Spanish by Atienza, Pons, Balaguer, and García-Merita in 2000 was administered, in which participants indicated their level of agreement or disagreement with the statements presented.

All questionnaires were collected using a Google Forms form, ensuring consistency in data collection. The decision to use social networks to disseminate the survey helped to obtain a more representative sample, thus ensuring the diversity of perspectives in the analysis of the Explanatory.

Model of Subjective Happiness in Adults in Tacna.

Data Analysis

In this study on the Explanatory Model of Happiness in Adults in Tacna, the statistical platform Jamovi version 2.3.28 Solid was used to perform a descriptive analysis of key variables, such as subjective happiness, emotional intelligence, and life satisfaction. Correlation analyses and regression models were conducted in order to explore the relationships and predictive ability between these variables. To evaluate the goodness of fit of the models, tests such as x²/

gl, approximate fit coefficients (CFI, TLI, RMSEA, RSMR), and beta coefficients were used. The use of Jamovi allowed additional statistical tests to be performed and the results to be effectively presented using graphs and tables.

The focus of the research is aimed at understanding the factors that impact the subjective happiness of adults in the city of Tacna. For this purpose, three explanatory models were developed that incorporate variables related to emotional intelligence and life satisfaction.

RESULTS

The study employed three structural equation models to examine the proposed theoretical relationships. The endogenous variable “Subjective Happiness” uses four items on a seven-point Likert scale. The exogenous variables included “emotional intelligence,” which encompassed six dimensions (well-being, self-control, emotionality, sociability, self-motivation, and adaptability), and “life satisfaction,” consisting of five items with seven-point Likert responses.

Table 5
Evaluation of model fit with respect to different indices.

Model	X ² /gl	CFI	TLI	PNFI	AIC	SRMR	RMSEA
Model 1	1,644	0,933	0,919	0,702	0,00	0,076	0,058
Model 2	1,527	0,951	0,939	0,709	0,00	0,074	0,053
Model 3	1,438	0,959	0,949	0,706	0,00	0,071	0,048

Table 5 presents a detailed analysis of the statistical models. In Model 1, appropriate fit indicators are evident, such as the Chi-square ratio over degrees of freedom (X²/GL) of 1.644, indicating a moderate discrepancy between the observed and expected data. The Comparative Fit Index (CFI) is 0.933, the Tucker-Lewis Index (TLI) is 0.919, and the Parsimony Normalized Fit Index (PNFI) is 0.702. The Standardized Root Mean Square Residual (SRMR) and Root Mean Squared Error of Approximation (RMSEA) are 0.076 and 0.058, respectively. In Model 2, the F4 predictor was removed, leading to improvements in several indicators. The Chi-square ratio over degrees of freedom (X²/gl) was reduced to 1.527, with Comparative Fit Index (CFI) and Tucker-Lewis Fit Index (TLI) of 0.951 and 0.939, respectively, indicating an acceptable fit. The Parsimony-

Normed Fit Index (PNFI) was 0.709, with SRMR of 0.074 and RMSEA of 0.053, both indicating a good fit relative to Model 1. In Model 3, a covariance between the emotional intelligence dimensions “AU and EE” was introduced, resulting in further improvements in the indicators. The Chi-square ratio over degrees of freedom (X²/gl) was 1.438, indicating a moderate deviation between the observed and expected data. The comparative fit index (CFI) and Tucker-Lewis fit index (TLI) were 0.959 and 0.949, respectively, indicating a robust fit. The Parsimony-Normed Fit Index (PNFI) was 0.706, suggesting a moderately complexity-adjusted fit, with SRMR of 0.071 and RMSEA of 0.048, both indicating a robust fit. In summary, Model 3 exhibited superior results compared to Models 1 and 2, evidencing a more robust fit and a relative improvement in model quality.

Figure 1

Explanatory model analyzing the relationship between all variables.

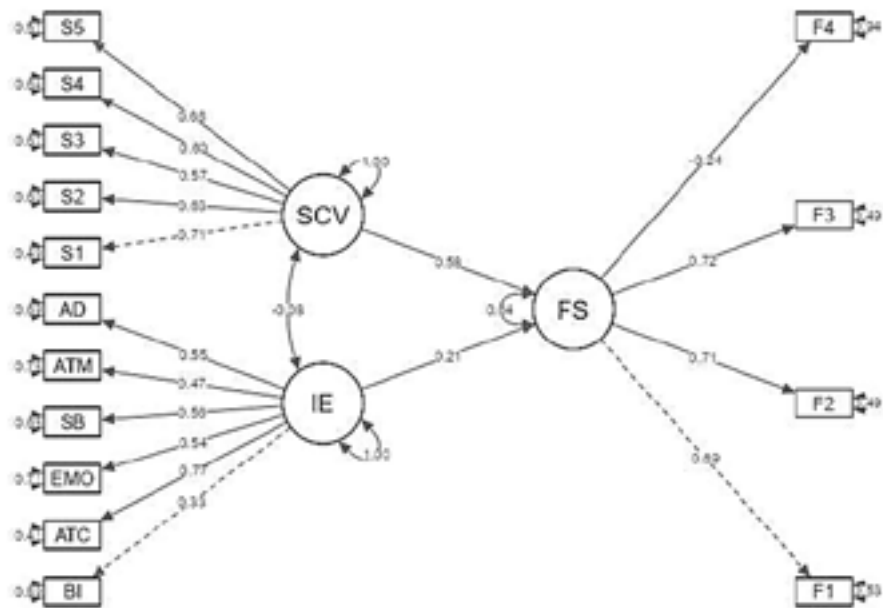

Figure 2

Explanatory model that analyzes the relationship between all variables eliminating item F4.

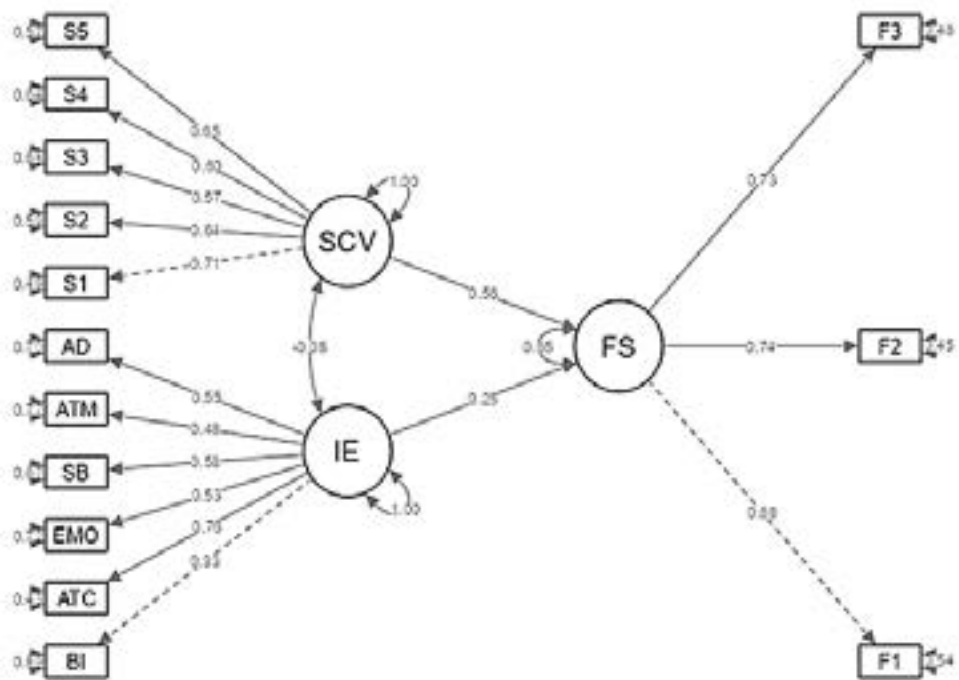

Figure 3

Explanatory model that analyzes the relationship between all variables and their covariance between the dimensions of emotional intelligence “AU and EE”.

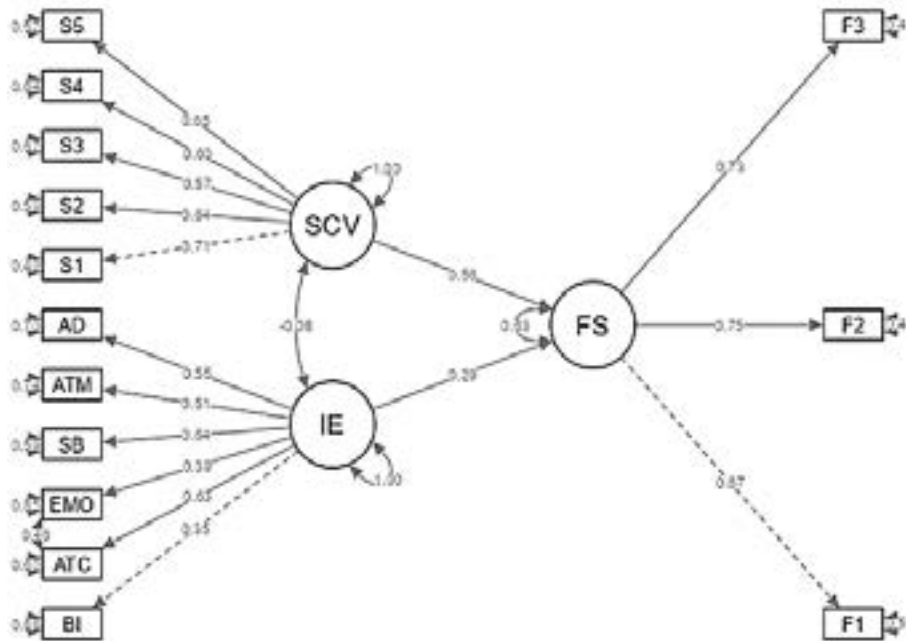

Table 6

Influence of emotional intelligence and life satisfaction on happiness in adults.

Predicha	Predictor	β	z	p
FS	IE	0.29	2.16	<.001
FS	SCV	0.56	4.87	<.001

*Note: FS=Subjective Happiness; EI=Emotional Intelligence; SCV=Satisfaction with Life.

Based on the fit indices presented in Table 6, Model 3 emerges as the most advantageous option. This model, which incorporates the covariation between the AU and EE dimensions, reveals substantial improvements, which seem to contribute positively to the explanatory power of the model, supporting its selection as the most robust and appropriate alternative to represent the relationships between the variables considered. Thus, emotional intelligence emerges as a significant predictor of subjective happiness with a p less than 0.005. At the same time, life satisfaction is also positioned as a valid predictor of subjective happiness, with a p less than 0.005 and a beta of 0.56.

The bivariate correlation analysis, as illustrated in Figure 4, reveals a low positive correlation of 0.21 between the variables “subjective happiness” and “emotional intelligence,” with a p-value of 0.004, indicating a statistically significant correlation. On the other hand, the relationship between “emotional intelligence” and “life satisfaction” exhibits a very low negative correlation of -0.141, with a p-value of 0.051, suggesting insufficient evidence to affirm a significant correlation between intelligence and satisfaction. Regarding the correlation between “subjective happiness” and “life satisfaction,” this is minimal, registering a value of 0.09, with an associated p-value of 0.215, leading to the conclusion that no significant correlation between happiness and satisfaction is observed.

Figure 4

Correlation matrix to compare subjective happiness, emotional intelligence and life satisfaction.

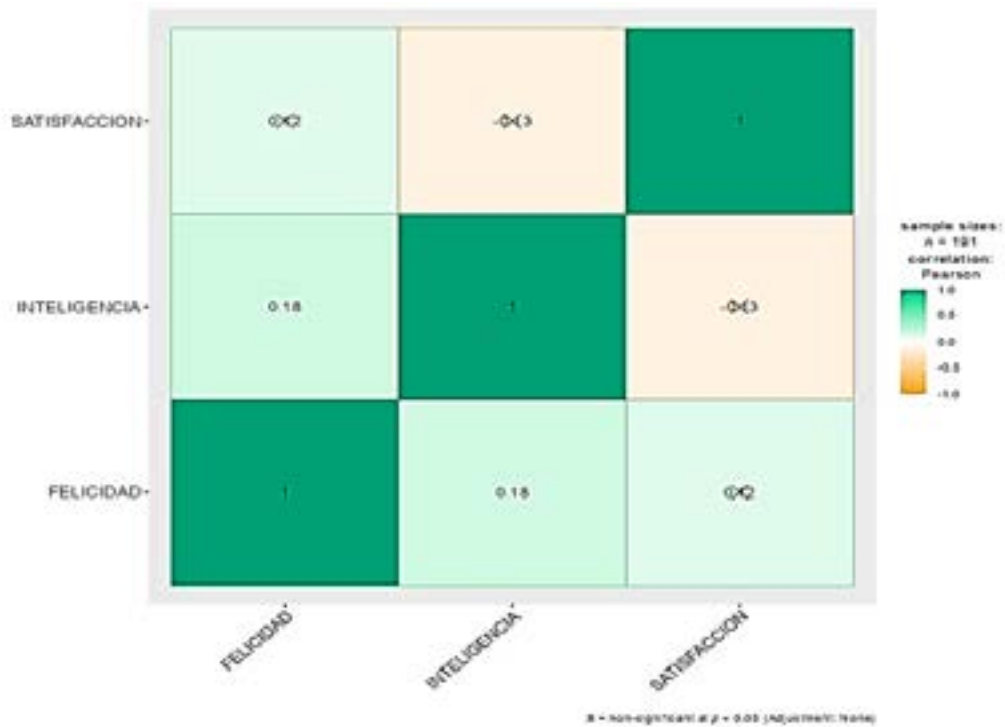

In Figure 5 of the Correlation Matrix, designed for the comparison between subjective happiness, emotional intelligence, and life satisfaction, a particular result stands out. Emotional intelligence shows a significant, albeit low, correlation of 0.18 with subjective happiness.

Figure 5

Correlation matrix to compare subjective happiness and emotional intelligence.

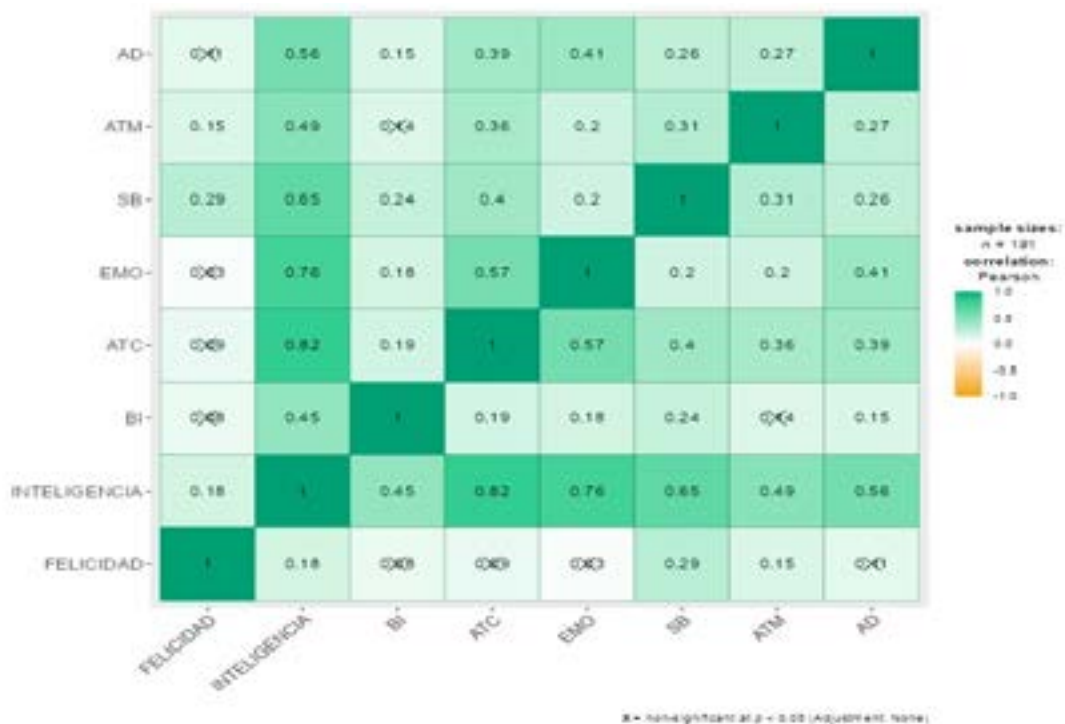
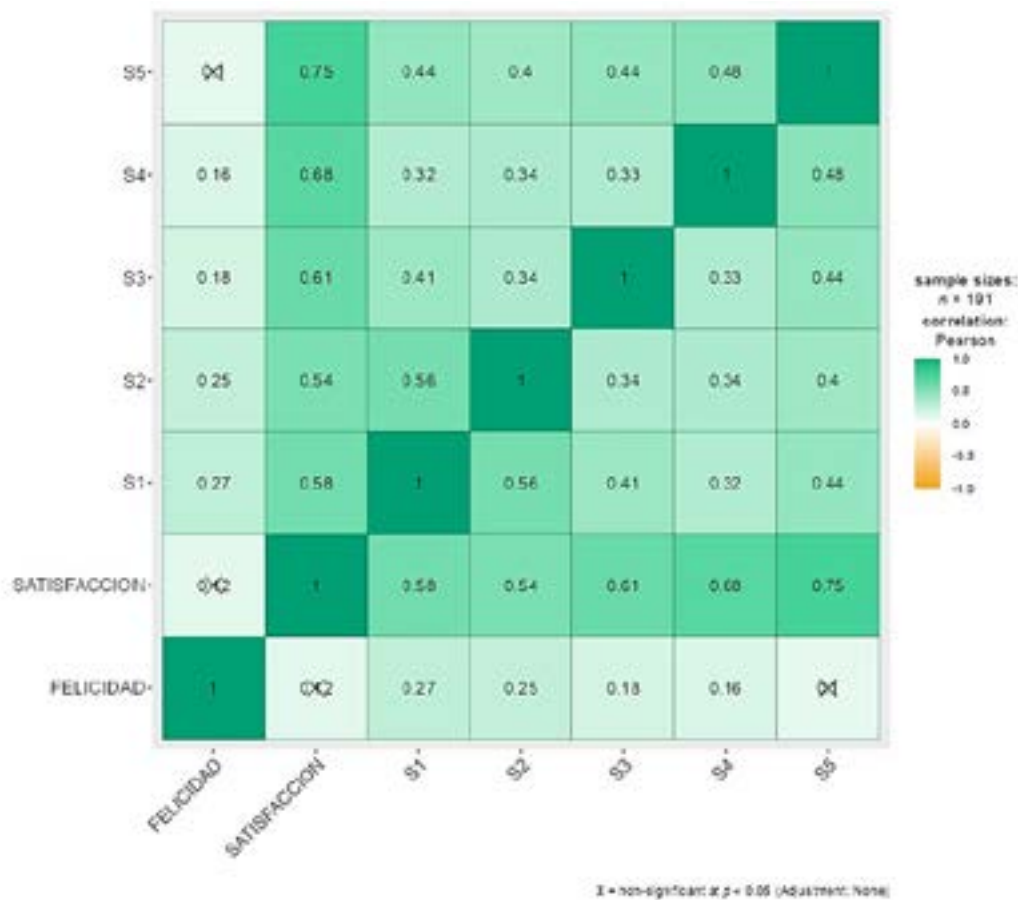

Figure 6, pertaining to the correlation matrix contrasting subjective happiness and emotional intelligence, shows several noteworthy results. A robust correlation of 0.82 is evident between the ATC dimension and emotional intelligence, as well as a significant correlation of 0.76 between the EMO dimension and emotional intelligence. In contrast, subjective happiness presents a more modest correlation, with a value of 0.29

in relation to the SB dimension. In addition, a low correlation of 0.15 is observed between the ATM dimension and subjective happiness. These findings suggest variable relationships between the various dimensions analyzed, underscoring the strong connection between the ATC dimension and emotional intelligence and a more tenuous relationship between subjective happiness and the SB dimension.

Figure 6

Correlation matrix for comparing subjective happiness and satisfaction with life.



DISCUSSION

The study addressed the assessment of subjective happiness by applying the respective scale. It examined its relationships with emotional intelligence and life satisfaction in a sample of 191 adults living in Tacna. Overall, the findings suggest that subjective happiness emerges as a significant predictor of emotional intelligence. This interaction between subjective happiness, emotional intelligence, and life satisfaction in adults has been the subject of study in several investigations, including that of Rahimi (2019),

who evidenced connections between subjective happiness, emotional intelligence, and life satisfaction in adults, showing a more robust correlation with emotional intelligence (0.31) and a lower correlation with life satisfaction (0.21). Similarly, Stamatopoulou et al. (2016) found statistically significant associations between subjective happiness and both emotional intelligence (0.68) and life satisfaction (0.63), which pointed to convergent validity with related constructs.

Similarly, Hidalgo et al. (2023) conducted a study on the predictive ability of emotional

intelligence. They perceived social support on life satisfaction and happiness and found a substantial relationship between these factors and the prediction of subjective happiness and life satisfaction. They highlighted the importance of fostering the development of emotional intelligence and the promotion of healthy social networks, especially among young people, to improve their psychological well-being.

Additionally, statistically significant correlations were observed between all components of subjective happiness and aspects of emotional intelligence and life satisfaction, a result consistent with previous research (Azpiazu & Sarasa, 2015; Di Fabio & Kenny, 2011). This finding was predictable, given that a higher level of subjective happiness may contribute to the development of emotional intelligence and life satisfaction, which, in turn, may improve interpersonal relationships and social support networks.

Consistent with previous research by Prado et al. (2018), Lourdes and Pena (2011), and Guasp et al. (2020), regression analyses highlight the relevance of subjective happiness in its explanation by both emotional intelligence and life satisfaction. Thus, adults who possess adequate emotional identification and management tend to perceive themselves as happier and more satisfied. These results are consistent with previous findings indicating that emotional clarity constitutes a determining factor in predicting individual well-being (Lischetzke & Eid, 2017). Therefore, although some attention to emotions may be adaptive, excessive focus on emotions accompanied by ineffective emotional regulation may trigger a higher prevalence of negative emotional states (Martinez et al., 2019).

Emotional intelligence, moreover, is associated with an improvement in interpersonal relationships and a greater manifestation of prosocial behaviors (Sarrionandia & Mikolajczak, 2018). These variables, in turn, are related to subjective well-being, given that maintaining frequent social relationships stands as a crucial aspect for individual satisfaction and happiness within the community environment.

CONCLUSIONS

When examining the fit of subjective happiness based on emotional intelligence and life satisfaction in adults living in Tacna, it was found that the indicators used need to be more adequate, which limits the ability of the explanatory model to fully address subjective happiness. Therefore, the hypothesis has been refuted.

When analyzing the influence of emotional intelligence on subjective happiness, it is observed that the latter acts as a relevant predictor of subjective happiness.

On the contrary, when evaluating the impact of life satisfaction on subjective happiness, it is evident that life satisfaction emerges as an effective predictor of subjective happiness since, when analyzing the confidence intervals, it is observed that the p-value is less than 0.005.

As for the correlation between subjective happiness, emotional intelligence, and life satisfaction, a significant correlation between subjective happiness (FS) and emotional intelligence (EI) stands out, with a p-value of 0.004. However, the correlation between emotional intelligence (EI) and life satisfaction (LCS) was not significant, with a p-value of 0.051, as was the correlation between subjective happiness (SF) and life satisfaction (LCS), which yielded a p-value of 0.215.

FUNDING

Self-financed

AUTHOR CONTRIBUTIONS

EGTS: Conception of the design, writing, processing, analysis and interpretation of the results, and review.

LMSG: Design conception, writing, processing, analysis and interpretation of results, and review.

YIB: Design concept, writing, processing, analysis and interpretation of results, and review.

CCSM: Design conception, writing, processing, analysis and interpretation of the results and review.

MAFE: Design conception, writing, processing, analysis and interpretation of results, and review.

COMPETING INTERESTS

The authors declare under oath that they have no conflict of interest in conducting this research.

REFERENCES

- Azpiazu, L. E., & Sarasa, M. (2015). Capacidad predictiva del apoyo social en la inteligencia emocional de adolescentes Predictive capacity of social support on emotional intelligence in adolescence. *European Journal of Education and Psychology*, 8(1), 23-29. <https://doi.org/10.1016/j.ejeps.2015.10.003>
- Brackett, M. A., & Salovey, P. (2006). Measuring emotional intelligence with the Mayer-Salovey-Caruso Emotional Intelligence Test (MSCEIT). *Psicothema*, 18(Suppl), 34-41. <https://psycnet.apa.org/record/2006-12699-005>
- Di Fabio, A., & Kenny, M. E. (2011). Emotional Intelligence and Perceived Social Support Among Italian High School Students. *Journal of Career Development*, 39(5). <https://doi.org/10.1177/0894845311421005>
- Diener, E. (1984). Subjective well-being. *Psychological Bulletin*, 95(3), 542-575. <https://psycnet.apa.org/doi/10.1037/0033-2909.95.3.542>
- Goleman, D. (1995). *Emotional intelligence*. Bantam Books.
- Guasp, C. M., Navarro, M. D., & Giménez, E. M. (2020). Emotional Intelligence, Empathy, Self-Esteem, and Life Satisfaction in Spanish Adolescents: Regression vs. QCA Models. *Educational Psychology*, 11. <https://doi.org/10.3389/fpsyg.2020.01629>
- Hidalgo, F. S., Martínez, Á. I., Sospedra, B. M., & Martí, V. M. (2023). Emotional Intelligence and Perceived Social Support: Its Relationship with Subjective Well-Being. *psychology*, 1-12. <https://doi.org/10.20944/preprints202310.2002.v1>
- Lischetzke, T., & Eid, M. (2017). The Functionality of Emotional Clarity: A Process-Oriented Approach to Understanding the Relation Between Emotional Clarity and Well-Being. *The Happy Mind: Cognitive Contributions to Well-Being*, 371-388. <https://doi.org/10.1007/978-3-319-58763-9>
- Lourdes, E. R., & Pena, M. N. (2011). Perceived Emotional Intelligence, Self-Esteem and Life Satisfaction in Adolescents. *Psychosocial Intervention*, 20(2), 227-234. <https://doi.org/10.5093/in2011v20n2a10>
- Lyubomirsky, S., Sheldon, K. M., & Schkade, D. (2005). Pursuing happiness: The architecture of sustainable change. *Review of General Psychology*, 9(2), 111-131. <https://sonjalyubomirsky.com/wp-content/themes/sonjalyubomirsky/papers/LSS2005.pdf>
- Martínez, M. M., Inglés, C. J., & Granados, L. (2019). Trait emotional intelligence profiles, burnout, anxiety, depression, and stress in secondary education teachers. *Personality and Individual Differences*, 142, 53-61. <https://doi.org/10.1016/j.paid.2019.01.036>
- Prado, G. V., Villanueva, B. L., & Górriz, P. A. (2018). Trait emotional intelligence and subjective well-being in adolescents: The moderating role of feelings. *Psicothema*, 30(3), 310-315. <https://doi.org/10.7334/psicothema2017.232>
- Rahimi, M. (2019). Propiedades psicométricas del cuestionario de inteligencia emocional rasgo persa (P-TEIQue). *Personalidad y diferencias individuales*, 99, 133-138. <https://doi.org/10.1016/j.paid.2016.04.098>
- Samper Lucena, E. (2011). Adaptación psicométrica del inventario de Texas revisado de duelo (ITRD) en población militar española joven adulta. *Sanidad militar*, 67(3). 291-298. https://scielo.isciii.es/scielo.php?script=sci_arttext&pid=S1887-85712011000400006

Sarrionandia, A., & Mikolajczak, M. (2018). A meta-analysis of the possible behavioural and biological variables linking trait emotional intelligence to health. *Health Psychology Review*, 14(2), 220-244. <https://doi.org/10.1080/17437199.2019.1641423>

Stamatopoulou, M., Galanis, P., & Prezerakos, P. (2016). Psychometric properties of the Greek translation of the Trait Emotional Intelligence Questionnaire-Short Form (TEIQue-SF). *Personality and Individual Differences*, 95, 80-84. <https://doi.org/10.1016/j.paid.2016.02.035>

Superintendencia Nacional de Educación Superior Universitaria. (2015). Sistema de información universitaria Tuni. *SUNEDU*. <https://www.tuni.pe/comunidad/estudiantes>